

Adjustments

⚠ Warning!

Before riding, always make sure that the basic settings made by Öhlins are according to recommended Set-up Data. Read about adjustments and setting up in the Öhlins Owner's Manual before you make any adjustments. Contact an Öhlins dealer if you have any questions about setting up the shock absorber.

⚠ Warning!

The adjustable end eye/bracket must not be threaded out more than that the groove is fully visible beneath the lock nut. This is maximum length. After adjusting, make sure that the lock nut is tightened.

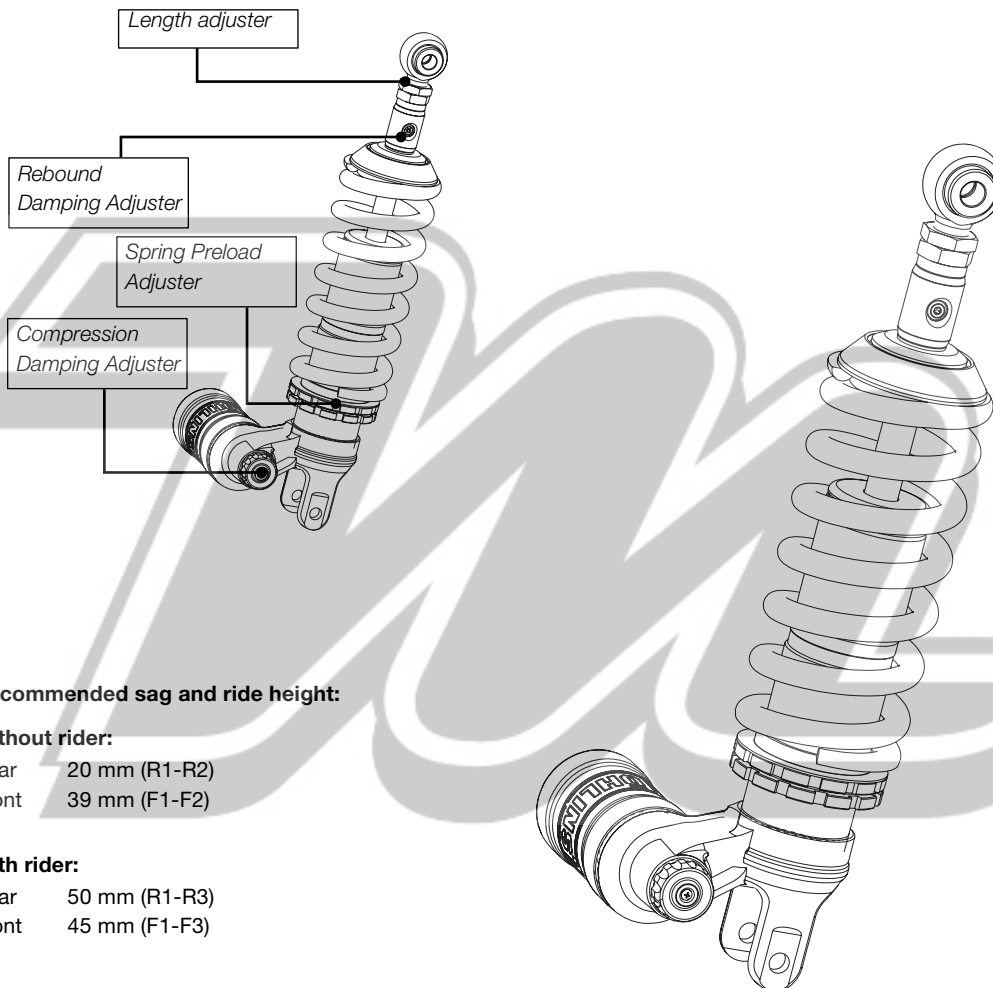
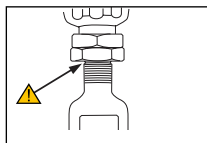

Before installing this product, check the contents of the kit. If anything is missing, please contact an Öhlins dealer.

Kit Contents

	Part No.	Pcs.
Shock abs S46PR1C1L	HA 137	1
C-spanner	00710-02	1
Öhlins Sticker yellow/blue	00192-01	2
Memo Notes Sticker	01180-01	1
Owner's Manual	07241-02	1

Please note that during storage and transportation, especially at high ambient temperature, some of the oil and grease used for assembling may leak and stain the packaging. This is in no way detrimental to the product, wipe off the excessive oil/grease with a cloth.

⚠ Warning!

Before installing this product, read the Öhlins Owner's Manual. The shock absorber is an important part of your vehicle and will affect the stability.

Set-up Data

Recommended set-up

Compression	16 clicks
Rebound	18 clicks
Spring Preload	9 mm

Spring

Part No.	Rate
01096-34	110 N/mm
Free Spring length	180 mm

Shock absorber data

Length	380 ⁺¹² / ₀ mm
Stroke	65

Recommended sag and ride height:

Without rider:

Rear	20 mm (R1-R2)
Front	39 mm (F1-F2)

With rider:

Rear	50 mm (R1-R3)
Front	45 mm (F1-F3)

Öhlins products are subject to continuous improvement and development, therefore, although these instructions include the most up-to-date information available at the time of printing, minor updates may occur.

To find the latest information contact your Öhlins distributor. Please consult your Öhlins dealer if you have any questions regarding the contents in this document.

Part no. HA137_0
Issued 2012-04-18



Shock Absorber for Husqvarna Nuda 900 HA 137

Mounting Instructions

© Öhlins Racing AB. All rights reserved. Any reprinting or unauthorized use without the written permission of Öhlins Racing AB is prohibited.

Öhlins Racing AB
Box 722
S-194 27 Upplands Väsby, Sweden
Phone +46 8 590 025 00
fax +46 8 590 025 80



www.ohlins.com



How to install

⚠ Warning!

It is advisable to have an Öhlins dealer install the shock absorber.

When installing, consult your Vehicle Service Manual.

1

Put the motorcycle on a workstand so that the rear wheel barely touches the ground.

⚠ Warning!

Make sure the vehicle is securely supported so that it will not tip.

2

Remove the seat and the plastic panel on the right side of the bike.

3

Remove the original shock absorber. Raise the wheel slightly so that the rear bolt can be removed.

👁 Note!

Before installing the Öhlins shock absorber clean the vehicle thoroughly.

4

Install the Öhlins shock absorber
- rebound adjuster and length adjuster at the upper bracket in the frame
- reservoir pointing to the left at the lower swing arm bracket

Raise the rear wheel slightly so that the rear bolt can be installed.

👁 Note!

If you want to access the rebound adjuster without removing the right side cover, it is possible to drill a small hole in the side panel for a small screwdriver.

👁 Note!

Lower the motorcycle so that the shock absorber is slightly compressed, before tightening the screws.

👉 Caution!

Make sure that all screws are tightened to the correct torque and that nothing fouls or restricts movement of the shock absorber when the suspension is fully compressed or extended.

5

Make sure that all removed parts are reinstalled in the same way as they were before the installation of the Öhlins shock absorber.

