



Kit Contents

Description	Part No	Pcs
Shock abs. Type 36DRL	HD 906	1
Tool pre-road adj. cruiser	03199-01	1
Sleeve	00123-13	2
Sleeve	00123-17	2
Sticker	00192-01	2
Washer 12,7/24/6 stainless	03118-08	8
Owners manual		1

Note!

Please note that this image is a general representation of the product and may differ slightly from your product.

Note!

Please note that during storage and transportation, especially at high ambient temperature, some of the oil and grease used for assembling may leak and stain the packaging. This is in no way detrimental to the product, wipe off the excessive oil/grease with a cloth.

Warning!

Before installing this product, read the Öhlins Owner's Manual. The shock absorber/front fork/steering damper is an important part of your vehicle and will affect the stability.

Shock absorber for Harley-Davidson Sportster

HD 906

Mounting Instructions



MOUNTING INSTRUCTIONS

⚠ Warning!

It is advisable to have an Öhlins dealer install the shock absorber/front fork/steering damper.

⚠ Warning!

If working on a raised vehicle, ensure it is securely supported so that it will not tip.

👁 Note!

Before mounting this product clean the vehicle thoroughly.

👁 Note!

When working on this product, always see the Vehicle Service Manual for vehicle specific procedures and important data.

1

Put the motorcycle on a workstand so that the rear wheel barely touches the ground.

2

Loosen and remove the standard shock absorber(s). See the motorcycle Workshop manual.

3

Fit the Öhlins shock absorber(s) in the same position as the standard shock absorber(s).

4

Continue your work according to the Owners manual, section adjustment.

👁 Note!

Lower the vehicle so that the suspension is slightly compressed before tightening the screws.

👋 Caution!

Ensure that all screws are tightened to the correct torque and that nothing fouls or restricts movement of the shock absorber/front fork/steering damper when the suspension is fully compressed or extended.

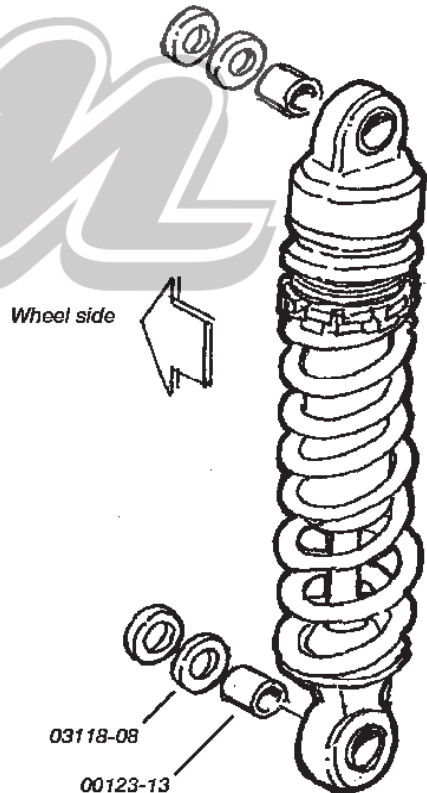

Normally the shock absorber is mounted with the cylinder head upwards. Check that there is enough clearance to other details both in loaded and unloaded position.

MOUNTING INSTRUCTIONS

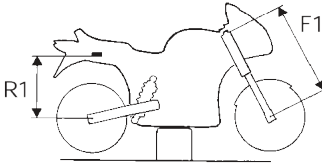

Bike on a stand.

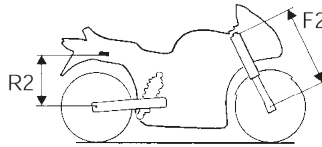

Bike on the ground.

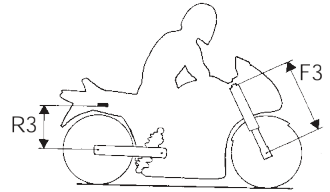

Bike with rider on.

Checking sag and ride height

Front suspension

F1. Bike on a stand with the suspension fully extended =

F2. Bike on the ground without rider =

F3. Bike on the ground with rider =

Free sag F1 - F2 =

Ride height F1 - F3 =

Rear suspension

R1. Bike on a stand with the suspension fully extended =

R2. Bike on the ground without rider =

R3. Bike on the ground with rider =

Free sag R1 - R2 =

Ride height R1 - R3 =

ADJUSTMENTS

⚠ Warning!

Before riding, always make sure that the basic settings made by Öhlins are according to recommended Set-up Data. Read about adjustments and setting up in the Öhlins Owner's Manual before you make any adjustments. Contact an Öhlins dealer if you have any questions about setting up.

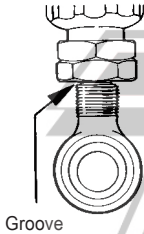

SET-UP DATA

Length	336	mm
Stroke	77	mm
Rebound	14	clicks
Spring preload	17	mm



👁 Öhlins products are subject to continuous improvement and development, therefore, although these instructions include the most up-to-date information available at the time of printing, minor updates may occur.

To find the latest information contact an Öhlins distributor. Please contact Öhlins if you have any questions regarding the contents in this document.

Part no. MI_HD906_1
Issued 2015-06-08

© Öhlins Racing AB. All rights reserved. Any reprinting or unauthorized use without the written permission of Öhlins Racing AB is prohibited.

Öhlins Racing AB
Box 722
S-194 27 Upplands Väsby, Sweden
Phone +46 8 590 025 00
fax +46 8 590 025 80



www.ohlins.com