

Adjustments

⚠ Warning!

Before riding, always make sure that the basic settings made by Öhlins are according to recommended Set-up Data. Read about adjustments and setting up in the Öhlins Owner's Manual before you make any adjustments. Contact an Öhlins dealer if you have any questions about setting up the shock absorber.

Compression and Rebound Adjuster

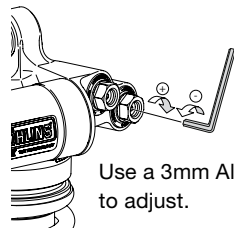

Use a 3mm Allen key to adjust.

Set-up Data

Recommended set-up

Compression	12 clicks
Rebound	12 clicks
Spring Preload	12 mm
Spring	21040-29
Spring Rate	90 N/mm
Spring; Free length	160 ⁰ / ₋₃ mm

Shock absorber data

Length	338 ⁺⁵ / ₋₁ mm
Stroke	64 mm

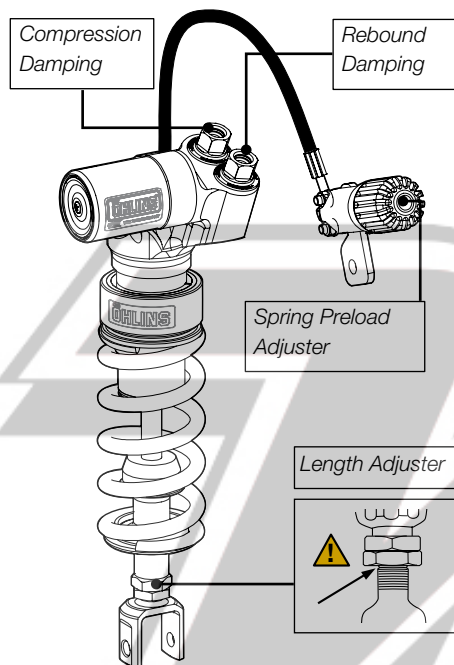

Recommended Sag and Ride Height

R1 - R2	17 mm
R1 - R3	31 mm
F1 - F2	30 mm
F1 - F3	39 mm

👁 Read about Free Sag and Ride height in the Öhlins Owner's Manual.

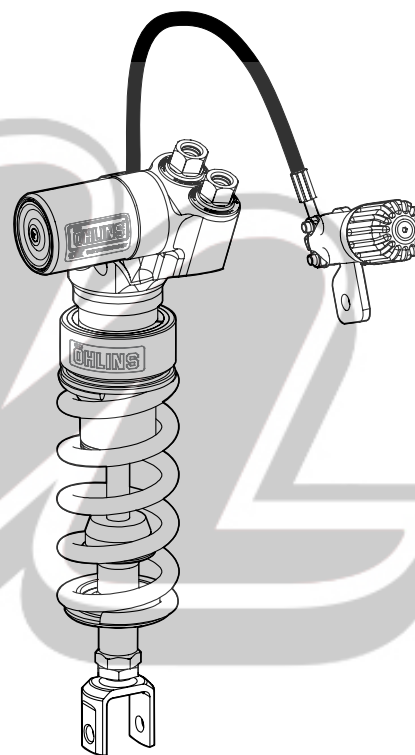

Before installing this product, check the contents of the kit. If anything is missing, please contact an Öhlins dealer.

Kit Contents

	Part No.	Pcs.
Shock Absorber	KA788	1
Tie rap	00231-01	2
Spacer 16/30/3	05669-03	2
Öhlins Sticker	00192-01	2
Memo Notes Sticker	01180-01	1
Owner's Manual	07242-01	1

Please note that during storage and transportation, especially at high ambient temperature, some of the oil and grease used for assembling may leak and stain the packaging. This is in no way detrimental to the product, wipe off the excessive oil/grease with a cloth.

⚠ Warning!

Before installing this product, read the Öhlins Owner's Manual. The shock absorber is an important part of your vehicle and will affect the stability.

👁 Öhlins products are subject to continuous improvement and development, therefore, although these instructions include the most up-to-date information available at the time of printing, minor updates may occur.

To find the latest information contact your Öhlins distributor. Please consult your Öhlins dealer if you have any questions regarding the contents in this document.

Part no. KA788_1
Issued 2011-01-21



Shock Absorber for Kawasaki ZX10R KA 788

Mounting Instructions

© Öhlins Racing AB. All rights reserved. Any reprinting or unauthorized use without the written permission of Öhlins Racing AB is prohibited.

Öhlins Racing AB
Box 722
S-194 27 Upplands Väsby, Sweden
Phone +46 8 590 025 00
fax +46 8 590 025 80



www.ohlins.com



⚠ Warning!

It is advisable to have an Öhlins dealer install the shock absorber.

When installing, read the Vehicle Service Manual.

1

Put the motorcycle on a workstand so that the rear wheel barely touches the ground.

⚠ Warning!

Make sure the vehicle is securely supported so that it will not tip.

2

Remove the lower covers.

3

Remove the lower and the upper screws of the original shock absorber.

4

Remove the original shock absorber from the left side of the vehicle.

👁 Note!

Recommendation! Before installing the Öhlins shock absorber:

- Clean the vehicle thoroughly
- Adjust the length of the shock absorber (check the headlight angle after adjusting the length!)

5

Remove the upper shock mount and exchange the original 10 mm spacer with the two 3mm spacers provided.

6

Install the Öhlins shock absorber. First, fasten the upper screw, then the lower. Use the original screws, do not tighten yet.

👁 Note!

Lower the motorcycle so that the shock absorber is slightly compressed, before tightening the screws.

7

Tighten the upper and the lower screws.

8

Reinstall the lower covers.

9

Install the hydraulic preload adjuster on the inside of the silencer mounting point. Use the original screw and nut. Fasten the hose with the tie-raps provided in this kit.

👁 Note!

Make sure that nothing interferes with the hose and the adjuster when the rear wheel suspension is fully extended/compressed.

10

Read more about the shock absorber and its settings in your Öhlins Owner's Manual.

⚠ Warning!

Make sure that all screws are tightened to the correct torque and that nothing fouls or restricts movement of the shock absorber when the suspension is fully compressed or extended.

👁 Note!

Before riding, always ensure that the basic settings made by Öhlins are intact.

