

Owners Manual

Mounting instructions Öhlins shock absorber kit
KT 295 for KTM SX 400/520 2002

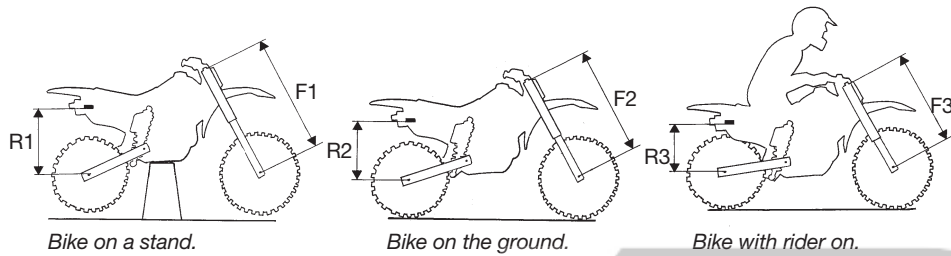

Setup data

Lenght	407.5 mm
Stroke	103 mm
Rebound adjustment	20 clicks
Compression adjustment	15 clicks
High speed comp. adj	3 turns
Preload	5 mm
Free sag, rear	30 mm
Ride height, rear	100 mm
Front fork position (top surface above triple clamp)	4 mm
Front fork adjustment	std.
Recommended fork springs	std.

Checking sag and ride height

Front suspension

F1. Bike on a stand with the suspension fully extended =

F2. Bike on the ground without rider =

F3. Bike on the ground with rider =

Free sag F1 - F2 =

Ride height F1 - F3 =

Rear suspension

R1. Bike on a stand with the suspension fully extended =

R2. Bike on the ground without rider =

R3. Bike on the ground with rider =

Free sag R1 - R2 =

Ride height R1 - R3 =

NOTE!

*If ride height is higher than recommended, softer spring/springs must be used.
If ride height is lower than recommended, harder spring/springs must be used.
Contact your Öhlins dealer for advice.*

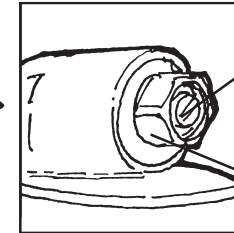
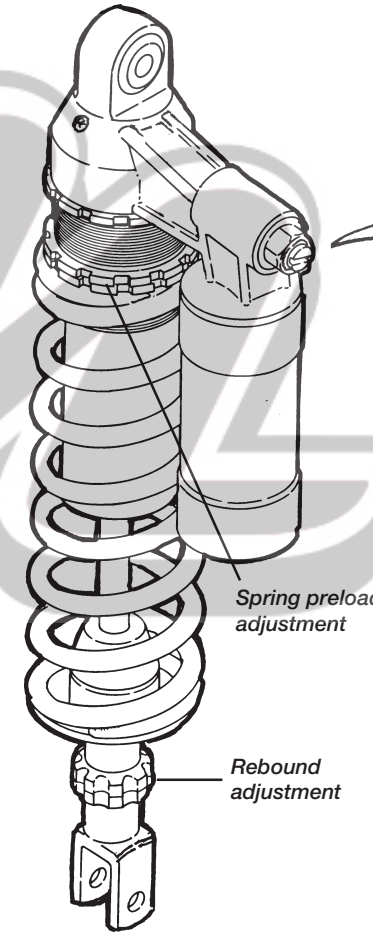

Adjusters

Your Öhlins shock absorber type 46 PRX (Q) features the following adjusters:

Compression damping:

Adjustments are made on top of the reservoir.
Low speed adjustments: Slotted centre screw
High speed adjustments: Hexagon screw.

Rebound damping

Adjuster wheel on the piston shaft above the end bracket.

Spring preload

Adjustment made by rings on cylinder house.
Use C-spanner.

When delivered the Öhlins shock absorber is dialed to recommended settings for the specific brand and make of the motorcycle. If you have changed the setting check like this:

The adjusters have a normal right hand thread. Turn clockwise to fully closed. Turn counter clockwise to open and count the clicks until you reach the recommended number of clicks.

Do not use too much force, delicate sealing surfaces can be damaged. Do use fingers only.

KT 295, issued 02 01 10



Öhlins Racing AB, Box 722, S-194 27 Upplands Väsby, Sweden.
Phone +46 8 590 025 00. Fax +46 8 590 025 80.
www.ohlins.com

© Öhlins Racing AB. All rights reserved. Any reprinting or unauthorized use without the written permission of Öhlins Racing AB is prohibited. Printed in Sweden.



Safety signals

Important information concerning safety is distinguished in this manual by the following notations:



*The Safety alert symbol means:
Caution! Your safety is involved.*

⚠ WARNING!

Failure to follow warning instructions could result in severe or fatal injury to anyone working with, inspecting or using the suspension, or to bystanders.

CAUTION!

Caution indicates that special precautions must be taken to avoid damage to the suspension.

NOTE!

This indicates information that is of importance with regard to procedures.

Before installation

Öhlins Racing AB can not be held responsible for any damage whatsoever to shock absorber or vehicle, or injury to persons, if the instructions for fitting and maintenance are not followed exactly.

Similarly, the warranty will become null and void if the instructions are not adhered to.

⚠ WARNING!

1. Installing a shock absorber, that is not approved by the vehicle manufacturer, may affect the stability of your vehicle. Öhlins Racing AB cannot be held responsible for any personal injury or damage whatsoever that may occur after fitting the shock absorber. Contact an Öhlins dealer or other qualified person for advice.

2. Please study and make certain that you fully understand all the mounting instructions and the owners manuals before handling this shock absorber kit. If you have any questions regarding proper installation procedures, contact an Öhlins dealer or other qualified person.

3. The vehicle service manual must be referred to when installing the Öhlins shock absorber

Öhlins products are subject to continual improvement and development. Consequently, although these instructions include the most up-to-date information available at the time of printing, there may be minor differences between your suspension and this manual. Please consult your Öhlins dealer if you have any questions with regard to the contents of the manual.

NOTE!

During storage and transportation, especially at high ambient temperature, the oil and grease used for assembling may run out inside the packing and damage the expanded polystyrene packing material. This is not unusual and is in no way detrimental to the shock absorber.

Kit contents

Before installing the shock absorber, please check the contents of the kit, listed on the front page of this instruction. If anything is missing, contact your Öhlins dealer.

Description	Pcs.	Part No.
Shock absorber	1	KT 295
Sticker Öhlins	2	00197-01
Sticker memo notes	1	01180-01
C-spanner	1	00710-02
Owners manual	1	

Mounting instructions

1

Put the motorcycle on a stand so the rear wheel has ground clearance. Make sure it's steadily positioned and will not fall over.

⚠ WARNING!

- 1. It's advisable to have an Öhlins dealer or other qualified person to fit your shock absorber.*
- 2. Instructions in the vehicle service manual are to be followed when changing the shock absorber.*
- 3. When working on a lifted vehicle it must be securely supported to prevent it from falling.*

2

Loosen the lower and the upper attachment of the original shock absorber and remove it. Backwards and out to the right above the right swing.

3

Fit the Öhlins shock absorber in the same way as the original unit. Fasten it by using the two original bolts.

4

Continue your work according to the Owners Manual, section Adjustments

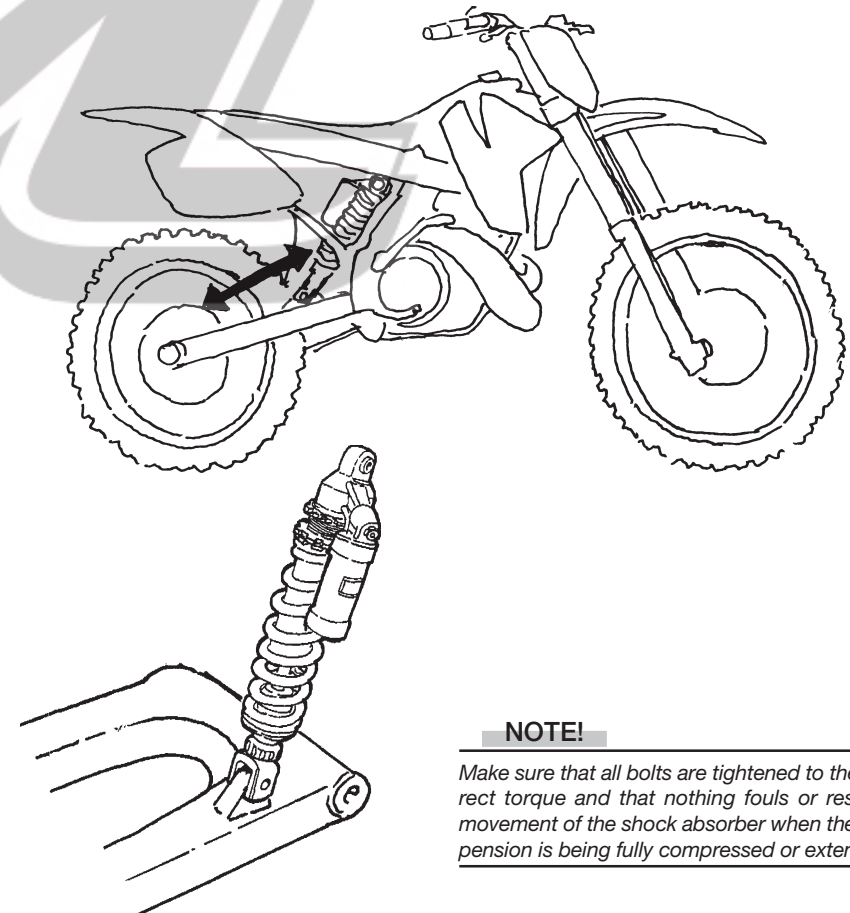

NOTE!

Make sure that all bolts are tightened to the correct torque and that nothing fouls or restricts movement of the shock absorber when the suspension is being fully compressed or extended.