

**7**

Loosen the lower and upper attachments of the shock absorber.

**8**

Lift the rear subframe upwards and take the shock absorber out by first lowering it and then pulling it back and upwards.

**9**

Fit the Öhlins shock absorber in the same position as the standard shock absorber.

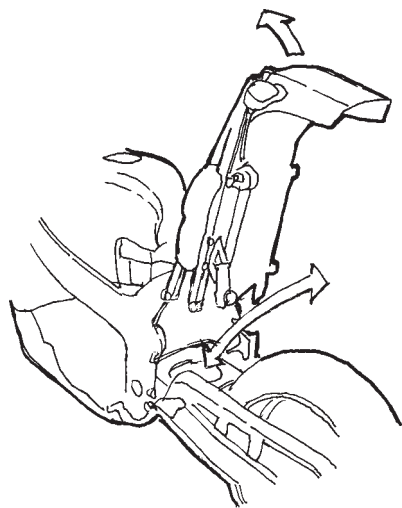

7

8

9

**10**

Fit the shock absorber first to the upper bracket and then to the triangle link.

**11**

Lift the wheel and reinstall the frame attachment of the triangle link.

**12**

Fix the rear sub frame in position.

**13**

Attach the prespanner adjuster to the silencer bracket and fasten the hose to the subframe with the tie-raps.

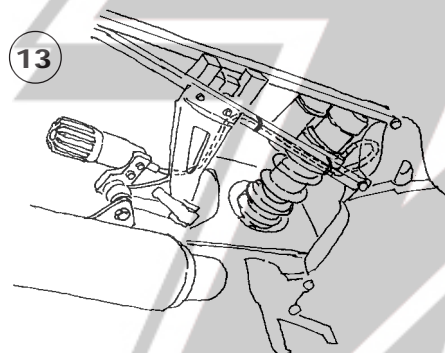

**14**

Remount rear side cover and put back the seat.

**15**

Continue your work according to the Owners Manual, section Adjustments.

**NOTE!**

*Make sure that all bolts are tightened to the correct torque and that nothing fouls or restricts movement of the shock absorber when the suspension is being fully compressed or extended.*

Traction, handling,  
comfort and safety



ADVANCED SUSPENSION TECHNOLOGY

Öhlins Racing AB, Box 722, S-194 27 Upplands Väsby, Sweden.

Phone +46 8 590 025 00, fax +46 8 590 025 80.

E-mail: info@ohlins.se

Web: www.ohlins.com

# Mounting instructions

## TR 004 - TRIUMPH SPRINT RS

### Kit content

Shock absorber 46 PRCS	TR 004	2
Sticker Öhlins Racing AB	00192-01	1
Memo sticker	01180-01	1
Screw	01046-25	1
Owners Manual		1
Ty-raps	00231-01	2

### Set-up data

Length	365 mm
Stroke	65 mm
Rebound adjustment	16 clicks
Compression adjustment	12 clicks
Preload	14 mm

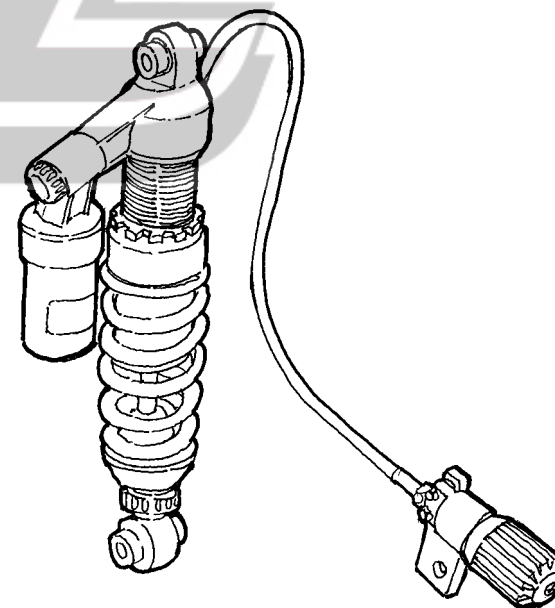

TR004 Issued 0002 28



ADVANCED SUSPENSION TECHNOLOGY

## Safety signals

Important information concerning safety is distinguished in this manual by the following notations.



The Safety alert symbol means: **Caution! Your safety is involved.**

### WARNING!

Failure to follow warning instructions could result in **severe or fatal injury** to anyone working with, inspecting or using the suspension, or to bystanders.

### CAUTION!

Caution indicates that special precautions must be taken to avoid damage to the suspension.

### NOTE!

This indicates information that is of importance with regard to procedures.

## Kit contents

Before installing the shock absorber, please check the contents of the kit, listed on the front page of this instruction. If anything is missing, contact your Öhlins dealer.

### NOTE!

During storage and transportation, especially at high ambient temperature, the oil and grease used for assembling may run out inside the packing and damage the expanded polystyrene packing material. This is not unusual and is in no way detrimental to the shock absorber.

## Before you start

### WARNING!

*Installing a shock absorber, that is not approved by the vehicle manufacturer, may affect the stability of your vehicle. Öhlins Racing AB cannot be held responsible for any personal injury or damage whatsoever that may occur after fitting the shock absorber. Contact an Öhlins dealer or other qualified person for advice.*

Öhlins Racing AB can not be held responsible for any damage whatsoever to shock absorber or vehicle, or injury to persons, if the instructions for fitting and maintenance are not followed exactly. Similarly, the warranty will become null and void if the instructions are not adhered to.

### WARNING!

*Please study and make certain that you fully understand all the mounting instructions and the owner's manuals before handling this shock absorber kit. If you have any questions regarding proper installation procedures, contact an Öhlins dealer or other qualified person.*

### WARNING!

*The vehicle service manual must be referred to when installing the Öhlins shock absorber.*

### NOTE!

*Öhlins products are subject to continual improvement and development. Consequently, although these instructions include the most up-to-date information available at the time of printing, there may be minor differences between your suspension and this manual. Please consult your Öhlins dealer if you have any questions with regard to the contents of the manual.*

## Mounting Instructions

### 1

Put the motorcycle on a stand so the rear wheel is clear of the ground. Make sure it's steadily fixed so it will not fall over.

### WARNING!

1. It's advisable to have an Öhlins dealer or other qualified person to fit your shock absorber.

2. Instructions in the vehicle service manual are to be followed when changing the shock absorber.

3. When working on a lifted vehicle it must be securely supported to prevent it from falling.

### 2

Remove the seat and seat cover by turning the lock key and lift it off.

### 3

Loosen the six screws to the rear side cover, remove the lamp bulbs and lift the cover off.

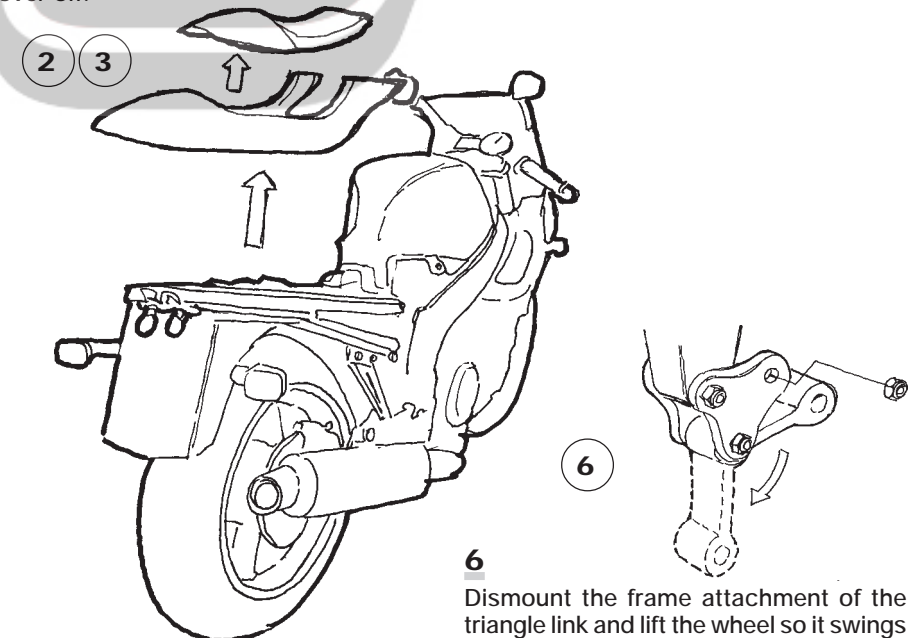

### 4

Loosen the upper screws to the rear sub frame and loosen and remove the lower bolts.

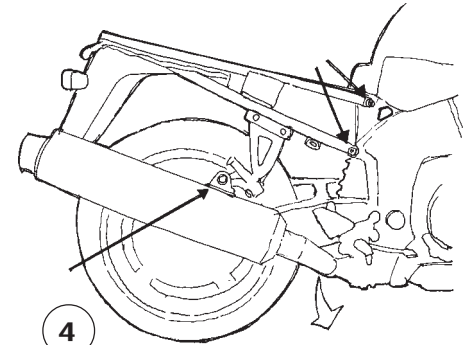

### 5

Loosen the silencer from its rear bracket

### 6

Dismount the frame attachment of the triangle link and lift the wheel so it swings down. Remove the battery. Loosen the fuel tank and move it a little bit forward to reach the upper shock mounting.

© Öhlins Racing AB.  
All rights reserved.

Any reprinting or unauthorized use without the written permission of Öhlins Racing AB is prohibited.  
Printed in Sweden.